

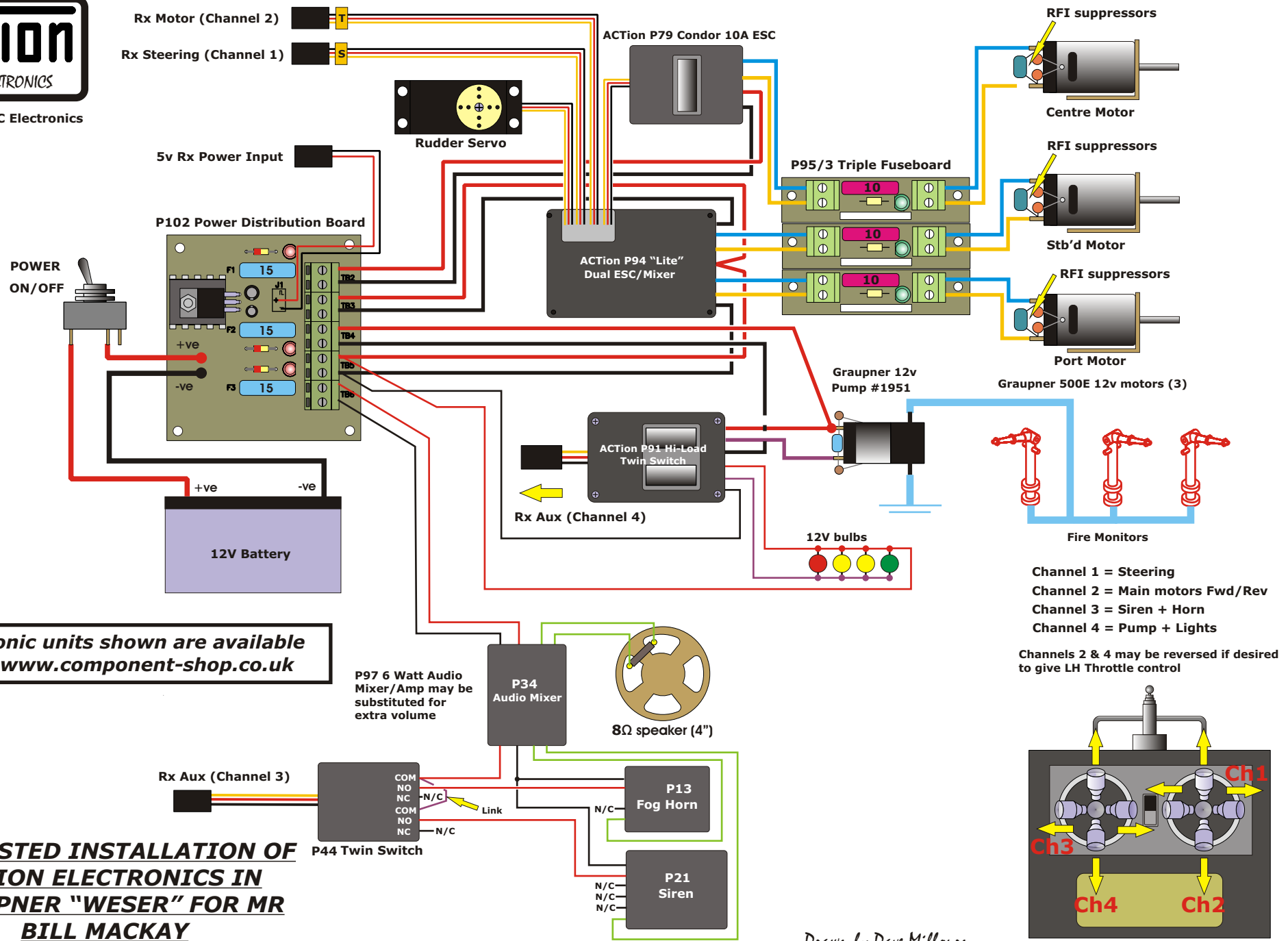

© Action R/C Electronics



Electronic units shown are available from www.component-shop.co.uk

SUGGESTED INSTALLATION OF ACTION ELECTRONICS IN GRAUPNER "WESER" FOR MR BILL MACKAY

- Channel 1 = Steering
 - Channel 2 = Main motors Fwd/Rev
 - Channel 3 = Siren + Horn
 - Channel 4 = Pump + Lights
- Channels 2 & 4 may be reversed if desired to give LH Throttle control

Drawn by Dave Milbourn