

P79/79S

**Condor 10A Autaset
Speed Controller**



The Condor P79 Autaset computer speed controller is a low-frequency, soft-start unit. A high quality, high performance electronic speed controller for use at 2 to 12 volts drive voltage and capable of handling a maximum current of 10 amps. Adjustable for gentle or rapid acceleration. Its very compact size and ease of use, together with state of the art performance will give you a controller that scale modellers have always wanted. It is suitable for 380/385; Speed 400 and low-current 500 type 3 pole or 5 pole motors.

THE P79 CONTROLLER IS NOT SUITABLE FOR USE WITH SEVEN TO TWELVE POLE MOTORS. WE HAVE PRODUCED THE P79S FOR THIS PURPOSE; THE WIRING IS IDENTICAL FOR BOTH.

MICROCOMPUTER & MOSFET DESIGN

Functions

- Radio control channels required
- Neutral setup
- Acceleration control
- Receiver voltage
- Maximum motor current
- Minimum motor voltage
- Maximum motor voltage
- Output connections

- Forward & Reverse/speed
- 1
- Autaset (allow 2 seconds)
- Moveable link
- 4.8 volts to 6 volts*
- 10 amps
- 2 volts
- 12 volts
- Screw connectors

*Do NOT use a 5-cell rechargeable pack or 6v Lead-acid battery to power the receiver *directly*; it will fatally damage the unit. Power *via* a regulated 5v supply such as a separate BEC or ACTION power board will be fine.

NOTE! THIS ESC IS NOT EQUIPPED WITH BATTERY ELIMINATOR CIRCUITRY (BEC).

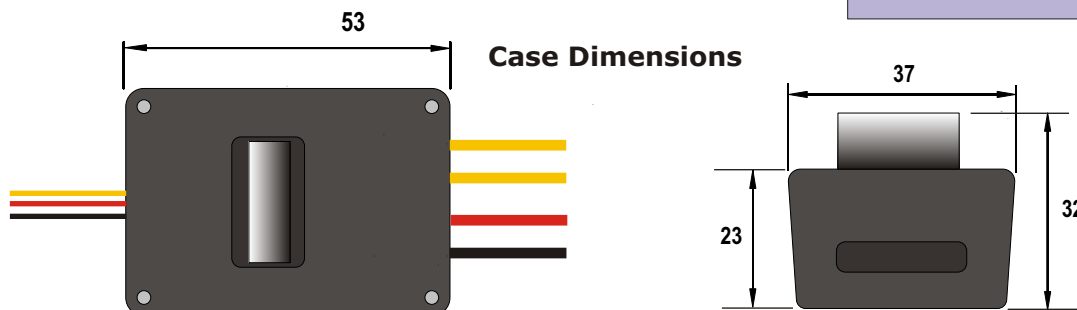
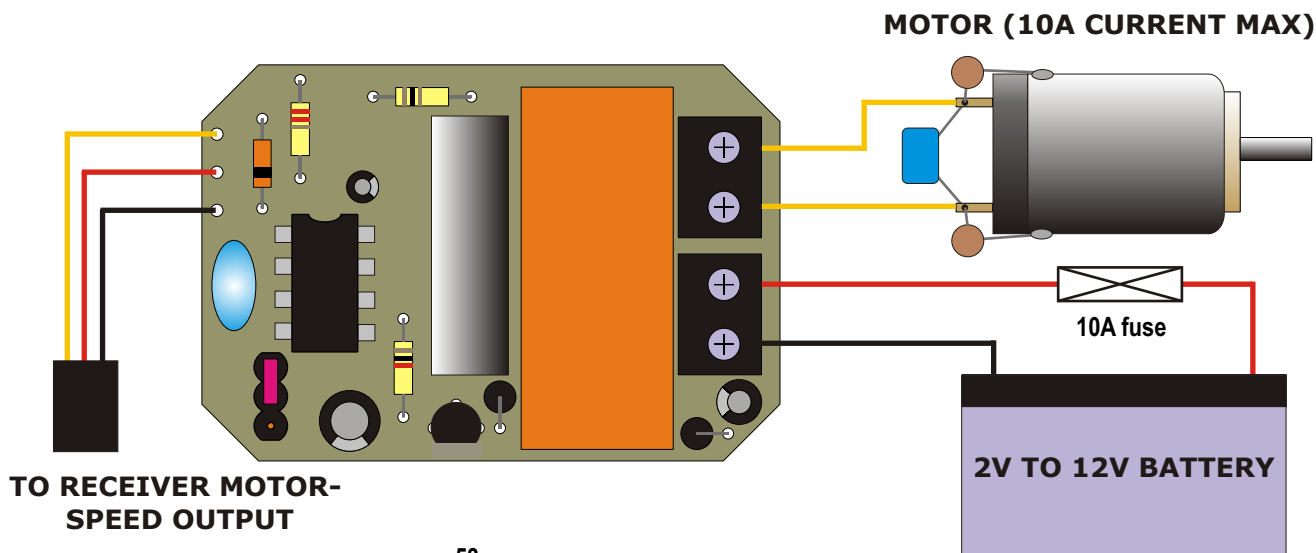

P79

Condor 10A Autaset Speed Controller



The Condor P79 Autaset computer speed controller is a low-frequency electronic speed controller for use at 2 to 12 volts drive voltage and capable of handling a maximum current of 10 amps. Adjustable for gentle or rapid acceleration. It is suitable for 380/385; Speed 400 and low-current 500 type 3 pole or 5 pole motors. **THIS CONTROLLER IS NOT SUITABLE FOR USE WITH SEVEN TO TWELVE POLE MOTORS.**

Functions	Forward & Reverse/speed
Radio control channels required	1
Neutral setup	Autoset (allow 2 seconds)
Acceleration control	Moveable link
Receiver voltage	4.8 volts to 6 volts*
Maximum motor current	10 amps
Motor voltage	2 volts to 12 volts
Output connections	Screw connectors
Case size (external)	53mm x 38mm x 23mm

***Do NOT use a 5-cell rechargeable pack or 6v Lead-acid battery to power the receiver *directly*; it will fatally damage the unit.**

Power *via* a regulated 5v supply such as a separate BEC or ACTION power board will be fine.

INSTALLATION AND SETUP

The case should be drilled and cut as per the diagram. The best way to cut out the hole for the heat-sink is to affix some masking tape to the lid where the cut-out is required, then mark it out with a sharp pencil. Drill a series of 3mm holes around the inside of the mark, join them up with a knife or side-cutters, then push out the waste material. Use a flat file to clean up the hole back to the mark and lastly remove the tape. Use Velcro pads to secure the case to the inside of the model.

Connect motor and battery leads. **Take care to connect the battery with correct polarity!!** (see layout and wiring diagram). We recommend 16AWG silicon cable for this job as it is very flexible and can carry up to 20A.

Plug servo lead into the speed/direction channel you wish to use.

Set the stick and trimmer to centre setting; switch on transmitter first and then the receiver. When switching off, Rx first followed by Tx. Allow **two seconds** for the autaset function to operate before moving the stick. The controller will now give the full range of forward and reverse speed. The link can be moved for gentle or rapid acceleration.

RECOVERY SERVICE

A recovery or repairs service ensures that you will not be left with a dead unit for any reason. The Service Charge for this kit is £13.00 including parts (including return shipping cost IN UK).

All returns should include full Credit Card details (Name & Address of cardholder, Card Number, Expiry Date and Card Security Number)

ACTION R/C ELECTRONICS, 1 Llwyn Bleddyn, Llanllechid, Bangor LL57 3EF, United Kingdom

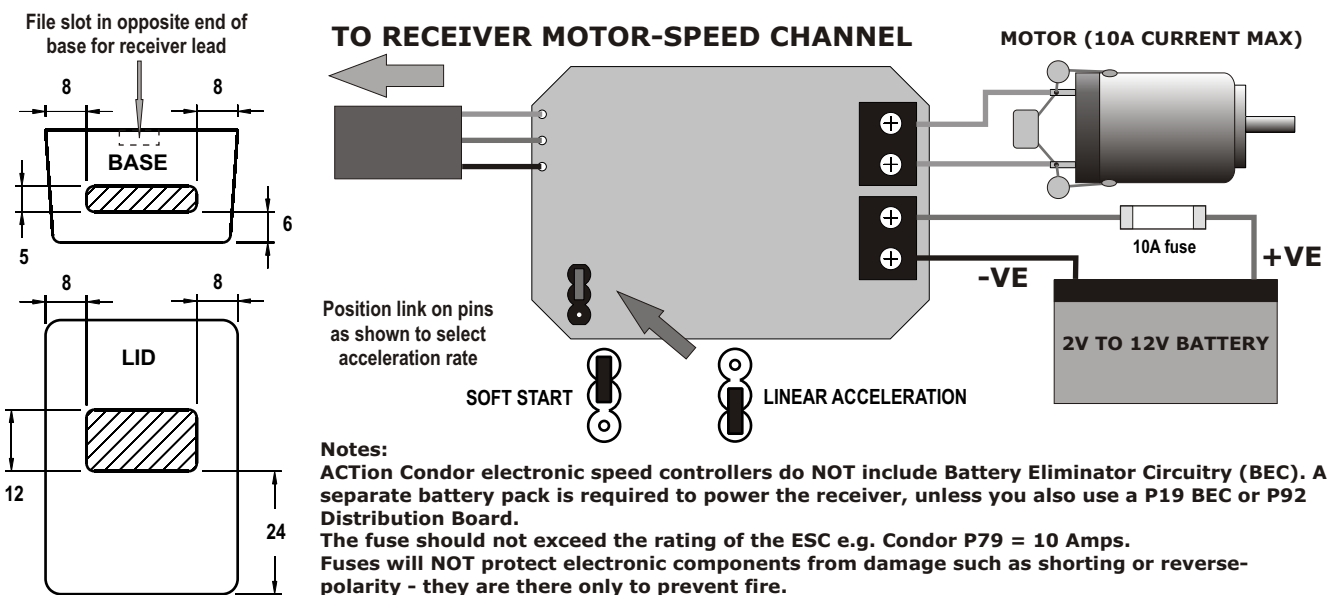

ACTION units shown are polarity-critical! Take care to connect them correctly!

The small print.....
 ACTION R/C Electronics guarantee all products to be free from manufacturing defects for 12 months from date of purchase. This does not cover suitability for specific applications; components worn or damaged by use, tampering or incorrect connection; alteration to original components; damage to batteries or other equipment through use; misuse, or shipping damage. Where goods are found to be faulty, the customer shall return them to ACTION R/C Electronics in their original condition and with their original instructions, packaging etc. Our liability is limited to repairing or replacing goods to their original specification and will not exceed the cost of the goods. By using the product the user accepts all liability. Where a fixed repair charge is applicable, ACTION R/C Electronics shall undertake repairs to the extent that they are judged economically viable. Where such is not the case then the customer will be offered the option of crediting the repair charge towards the cost of a new unit or having the faulty unit returned and the charge refunded (less the cost of return carriage). We reserve the right to modify this guarantee without notice.

P79S

**Condor 10A Autaset Speed Controller
Multi-pole motor version**



The Condor P79S Autaset computer speed controller is a low-frequency electronic speed controller for use at 2 to 12 volts drive voltage and capable of handling a maximum current of 10 amps. Adjustable for gentle or rapid acceleration. It is suitable for 380/385; Speed 400 and low-current 500 type 3 pole or 5 pole motors, but it has been specially designed to work with seven to twelve-pole motors such as Buhler, Pittman etc.

Functions	Forward & Reverse/speed
Radio control channels required	1
Neutral setup	Autaset (allow 2 seconds)
Acceleration control	Moveable link
Receiver voltage	4.8 volts to 6 volts*
Maximum motor current	10 amps
Motor voltage	2 volts to 12 volts
Output connections	Screw connectors
Case size (external)	53mm x 38mm x 23mm

***Do NOT use a 5-cell rechargeable pack or 6v Lead-acid battery to power the receiver *directly*; it will fatally damage the unit. Power *via* a regulated 5v supply such as a separate BEC or ACTION power board will be fine.**

INSTALLATION AND SETUP

The case should be drilled and cut as per the diagram. The best way to cut out the hole for the heat-sink is to affix some masking tape to the lid where the cut-out is required, then mark it out with a sharp pencil. Drill a series of 3mm holes around the inside of the mark, join them up with a knife or side-cutters, then push out the waste material. Use a flat file to clean up the hole back to the mark and lastly remove the tape. Use Velcro pads to secure the case to the inside of the model.

Connect motor and battery leads. **Take care to connect the battery with correct polarity!!** (see layout and wiring diagram). We recommend 16AWG silicon cable for this job as it is very flexible and can carry up to 20A.

Plug servo lead into the speed/direction channel you wish to use.

Set the stick and trimmer to centre setting; switch on transmitter first and then the receiver. When switching off, Rx first followed by Tx. Allow **two seconds** for the autaset function to operate before moving the stick. The controller will now give the full range of forward and reverse speed. The link can be moved for gentle or rapid acceleration.

RECOVERY SERVICE

A recovery or repairs service ensures that you will not be left with a dead unit for any reason. The Service Charge for this kit is £15.00 including parts (including return shipping cost IN UK).

All returns should include full Credit Card details (Name & Address of cardholder, Card Number, Expiry Date and Card Security Number)

ACTION R/C ELECTRONICS, 1 Llwyn Bleddyn, Llanllechid, Bangor LL57 3EF, United Kingdom

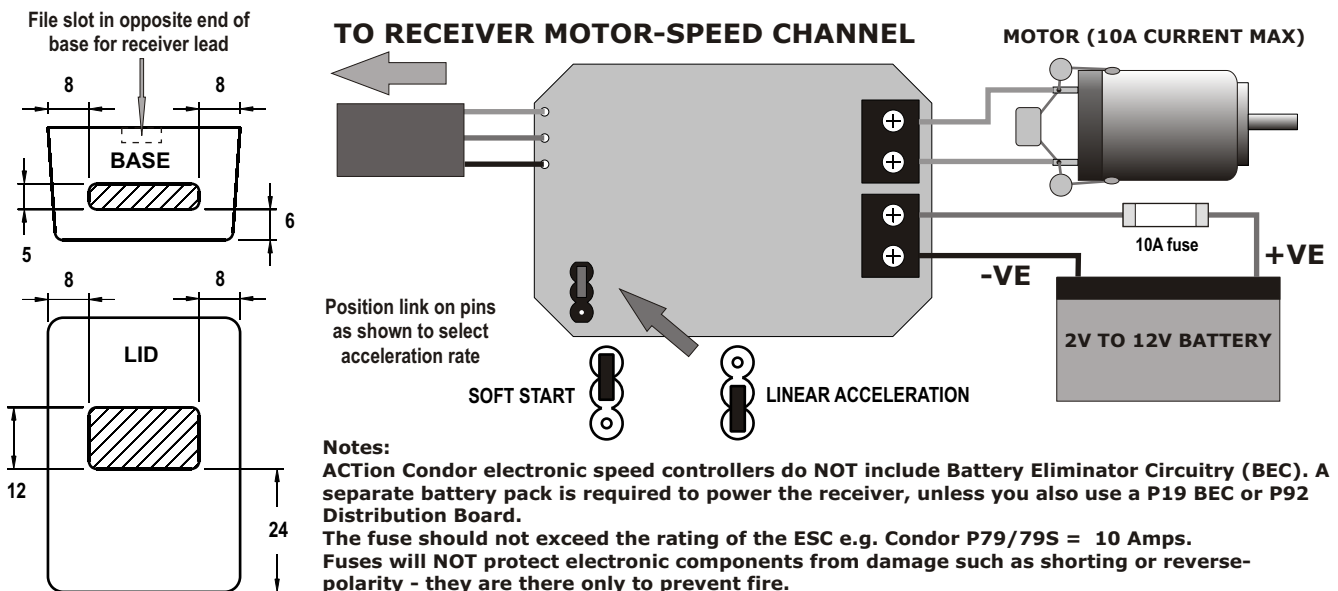

ACTION units shown are polarity-critical! Take care to connect them correctly!

The small print.....

ACTION R/C Electronics guarantee all products to be free from manufacturing defects for 12 months from date of purchase. This does not cover suitability for specific applications; components worn or damaged by use, tampering or incorrect connection; alteration to original components; damage to batteries or other equipment through use; misuse, or shipping damage. Where goods are found to be faulty, the customer shall return them to ACTION R/C Electronics in their original condition and with their original instructions, packaging etc. Our liability is limited to repairing or replacing goods to their original specification and will not exceed the cost of the goods. By using the product the user accepts all liability. Where a fixed repair charge is applicable, ACTION R/C Electronics shall undertake repairs to the extent that they are judged economically viable. Where such is not the case then the customer will be offered the option of crediting the repair charge towards the cost of a new unit or having the faulty unit returned and the charge refunded (less the cost of return carriage). We reserve the right to modify this guarantee without notice.



P79/79S CONDOR 10A SPEED CONTROLLERS
Instructions for Kit versions

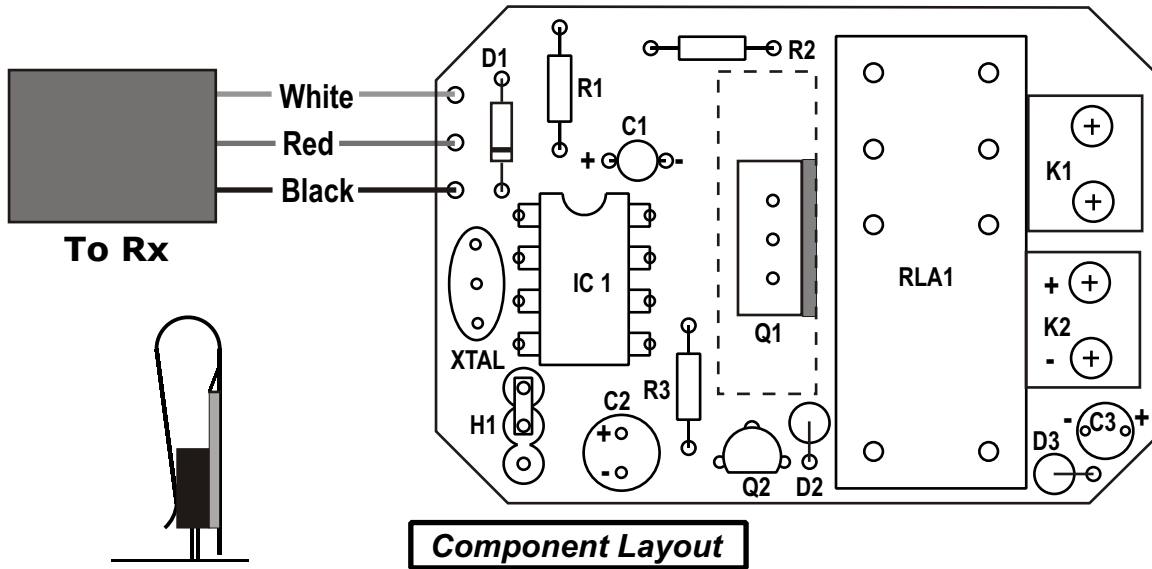

FITTING HEAT SINK ONTO Q1

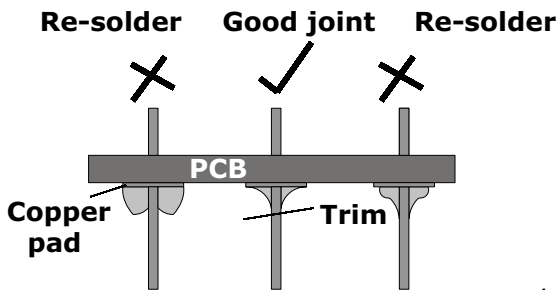

Soldering Tips

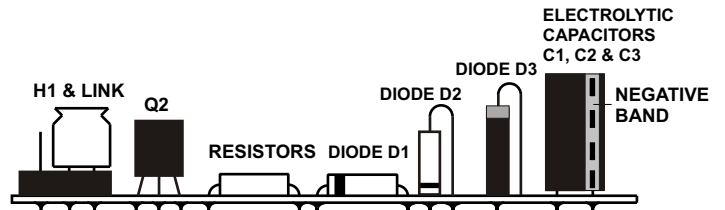

Component mounting details



Resistor colour bands

PARTS LIST

- IC1 PIC12C508/04 (PROGRAMMED) IC + 8 PIN IC socket (see notes on handling)
- Q1 MOS POWERFET NDP6060L (P79S = IPS031) (see notes on handling)
- Q2 2N7000 FET (see notes on handling)
- D1,2 Diode Type 1N4148 (Glass)
- D3 Diode Type 1N4003 (Black Plastic)
- XTAL 4.0 MHz solid state crystal (blue, 3 legs)
- R1 220 ohm resistor 1/4 watt (RED/RED/BROWN)
- R2 100 ohm resistor 1/4 watt (BROWN/BLACK/BROWN)
- R3 1K ohm resistor 1/8 watt (BROWN/BLACK/RED) Smallest resistor
- C1 0.47uF min radial electrolytic capacitor
- C2,3 10uF min radial electrolytic capacitor
- K1, K2 Twin screw-connector blocks
- H1 3-pin header and link
- CASE Type RX2008
- RLA 8 pin DPDT 16A relay
- PCB TYPE P79
- LEAD HiTec/JR generic type supplied, with alternative Futaba plug

P79 KIT INSTRUCTIONS

PCB

The PCB has an insulated (Component Side) and a tinned track side. Components are mounted on the insulated side and soldered on the track side. The PCB for this project is fully prepared and requires no additional work. It is manufactured from high-grade glass fibre with double thickness copper layer. Look carefully at the area of the PCB you are working on when soldering to ensure that you do not apply an extra connection with a splash of solder during the operation.

TOOLS

For construction you will require a soldering iron with a fine pointed bit and flux cored solder (22 SWG recommended); a small pair of wire cutters, a small screwdriver for screw connectors and a good level of light.

PARTS

DO NOT HANDLE ITEMS IN BLACK CONDUCTIVE FOAM AND CONDUCTIVE BAG UNTIL INSTRUCTED. (MOS DEVICES) THEY ARE SENSITIVE TO STATIC ELECTRICITY FROM YOUR BODY.

- The short bars with colour bands and a wire at each end are resistors. They are colour coded as shown on the drawing and the Parts List. There are only three values in this kit; R1 (220 Ohms) , R2 (100 Ohms) at 1/4 Watt and R3 is a 1K 1/8 Watt.
- The tubular electrolytic capacitors (C1, C2, C3) are marked with the value and working voltage, they also have a band down one side of the plastic sleeve with (-) Negative signs on it which signifies which leg goes to the negative. The opposite leg (long one) of the capacitor, of course, goes to the positive. Capacitor polarisations (+ and -) are clearly shown on the drawing.
- The 8-pin integrated circuit (IC1) is marked with its type code, see the drawing together with the Parts List. It is delivered in conductive foam and should be left in the foam until you are about to fit it. Being a MOS device, it can be damaged by static electricity and care must be exercised when handling. It is supplied with a socket. This will enable the builder to solder in the socket during construction, then fit the IC at the end of construction. The 3-legged black plastic moulded part with two rounded edges is a MOS transistor Q2 (marked BS170P or 2N7000).
- The other device which is prone to damage by static is the 3-legged black square moulding with an integrated thick metal panel (Q1). It is a MOS POWERFET, again, leave it where it is until required for fitting. It is supplied with a metal clip-on heat-sink (the bent aluminium part with a black coating). The heat-sink is fitted after Q1 has been soldered in place.
- The black plastic rod with a wire each end and the type code printed on it (1N4003) is a diode (D3). It also has a silver bar printed around one end which is used to identify which way round it goes. This is shown as a dark bar on the drawing. The other diodes (D1 & D2) are smaller glass components with a dark bar at one end. As with D3, this indicates which way round to fit it.
- The 3-legged blue part with something like 4.0 marked on it, is a type of crystal to ensure that the microcomputer is always running at exactly 4.0 MHz. It can be fitted either way round.
- The 8 pin low profile relay is easy to identify by its large orange casing. It will only fit one way round in the PCB.
- 2-way screw connectors are easily identified and are marked on the drawing as K1 and K2.
- The 3-pin header H1 is a small strip with 3 gold plated pins. It is used in conjunction with the 2-pin link to select gentle or rapid acceleration. The short end of the pins should be soldered through the holes in the PCB with the long ends remaining above for the red link.

CONSTRUCTION

I would suggest that you fit the socket for IC1 first, it will help to give you your bearings as to what goes where. Note the small notch at one end of the plastic moulding and ensure that it is fitted as shown in the drawing, soldering all pins carefully. The IC should be plugged into the socket as the last operation of construction.

- The resistors should be fitted as per the mounting details drawing. The drawing and the Parts List show how to read the colour codes. As each resistor is fitted and soldered, the spare wire should be cut off close to the PCB to keep the whole job looking tidy. Soldering Tips may help if you are inexperienced with a soldering iron. Note the little resistor is R3.
- Fit and solder the XTAL at this point (three legs, blue case) either way round. Trim off legs.
- Next component to be fitted should be the diodes D1, D2 & D3, **IMPORTANT** Bend the wire as per the drawing then solder as per the parts layout. If this is done exactly as per the drawing the component will be the right way round. Again cutting off the spare wires.
- The electrolytic capacitors, C1 (0.47uF), C2 & C3 (10uF) can now be fitted and this type has to be fitted the correct way round; the negative is marked on the component and the longer lead is positive. Positive and negative signs are marked on the layout diagram, to make sure you identify and connect it correctly.
- The two twin connector blocks can now be soldered into the four larger holes at one end of the PCB. Note that the wire insertion holes face to the outside of the PCB. Solder in the header H1, leaving long pins facing up to accept the link on. You can fit the link at this point
- Fit and solder the relay RLA1, push it right down to the PCB surface; it only goes one way round.
- **NOTES ON CMOS DEVICE HANDLING. USE A SHEET OF ALUMINIUM - COOKING METAL FOIL WILL DO.**
- Place it on the work surface. Place the PCB, solder side down on it. Place the BLACK CONDUCTIVE FOAM on it and rest your hands on it, holding them there while you read through this part of the instructions. The PCB, MOS I/C and you are now all at the same potential, i.e. any static voltage difference is now neutralised. Touch the soldering iron tip on to the metal sheet to neutralise any static it may have. Q1 is also a MOS device. The small 3 legged transistor Q2 can now be fitted and soldered. The shape, and hence fitting direction, is shown clearly on the drawing. Cut off the spare wires.
- Last component to solder is the POWERFET Q1. Ensure that the legs go right down to the PCB as far as possible; they are a little wider at the top and will go no further than that. When soldered and trimmed, push the heat-sink, tapered end first, down onto the POWERFET until the little stop inside the heat-sink touches the top of the metal tab.
- Time to fit the IC in its socket. Ensure that the notch is exactly as per the drawing .
- A 3-wire lead is supplied to connect the unit to the receiver. Connect the coloured leads as per the drawing. That's it; the PCB construction is complete. The rear of the board can now be cleaned with something like an old toothbrush and some spirit cleaner. Meths will do but Isopropyl is very much better. Then check all over the soldered side of the board for good joints and no solder bridges between tracks or round pads.

CASE

Time now to tackle the case, not a lot to it really; see the drawing. File out a narrow section at the top of the servo-lead end of the case body for the servo lead. The drawing gives the dimensions and details for both the heat-sink cut-out and wiring cut-out. The large cut-out for the heat-sink is best done by drilling a series of holes around the inside of the rectangular area, then joining them up with a sharp blade or small file to remove the ABS. Clean up the edges with a flat file. When you are sure that everything is as it should be, you can proceed to testing.

TESTING

Having built the unit it's simply a matter of connecting two wires from the Block marked MOTOR to your motor, then a RED (+) power lead and a BLACK (-) power lead to whatever battery pack you are using. *Note that the heat-sink must not be shorted to any power lead, this can blow the POWERFET.*

WARNING - DO NOT use the black foam as packing in the finished unit, it is CONDUCTIVE.

P79 CONDOR 10/2 AUTOSET SPEED CONTROLLER

(Note: The construction sequence of P79S Condor 20/2 SMARTFET version is identical)

PHOTOGRAPHIC BUILD SEQUENCE FOR KIT VERSION ONLY

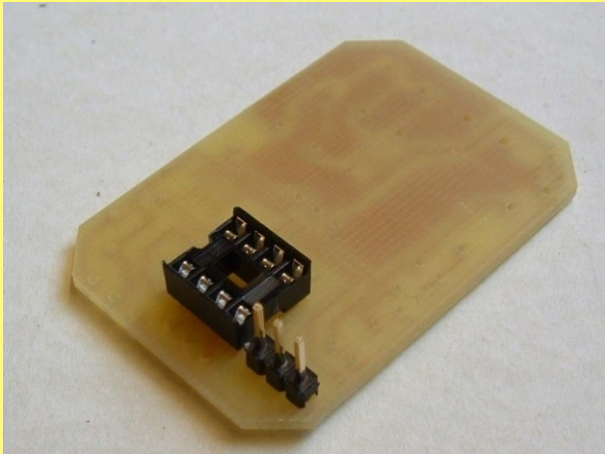

PICTURE 1: PCB with I/C socket and 3-pin header fitted

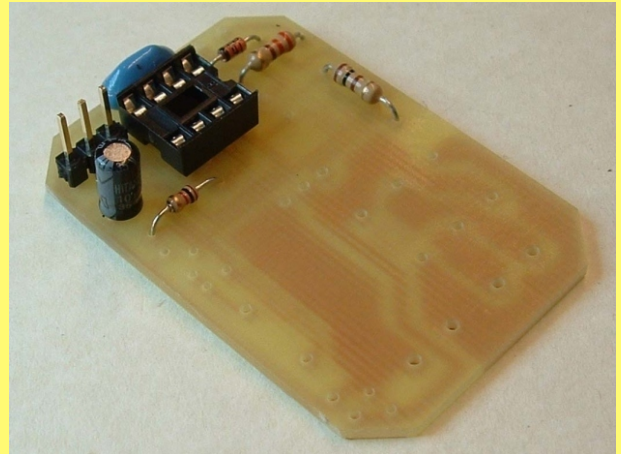

PICTURE 2: Diode, capacitor, resistors and crystal added

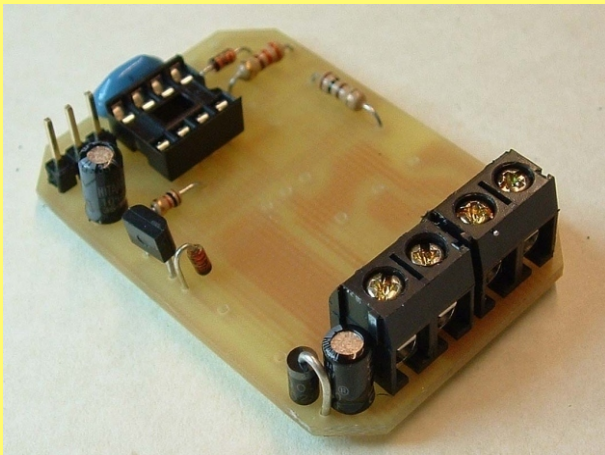

PICTURE 3: Small MOSFET; remaining diodes capacitors & terminal blocks fitted

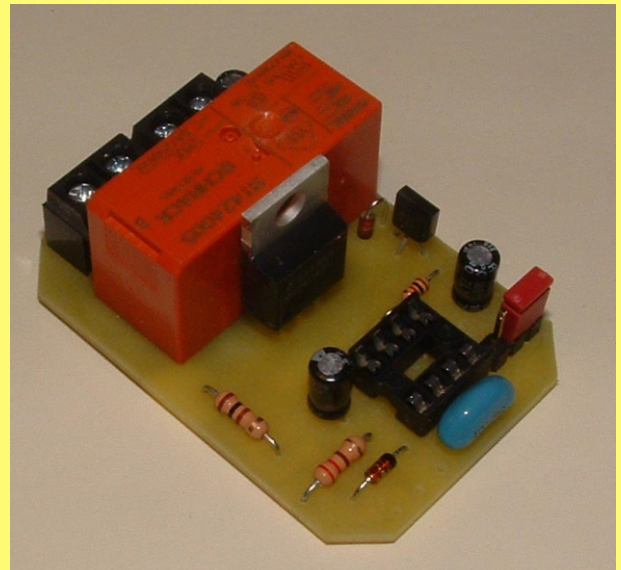

PICTURE 4: Fit relay and main power MOSFET. NB! ANTI-STATIC PRECAUTIONS REQUIRED

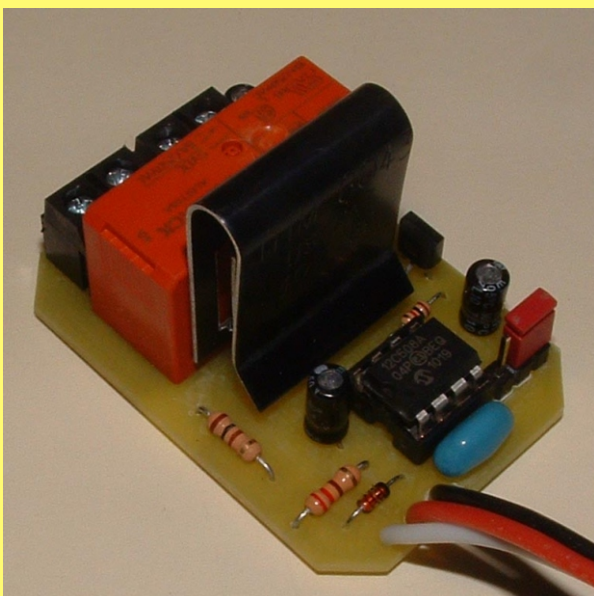

PICTURE 5: Clip-on heat-sink; fit receiver lead and plug in PIC chip last.

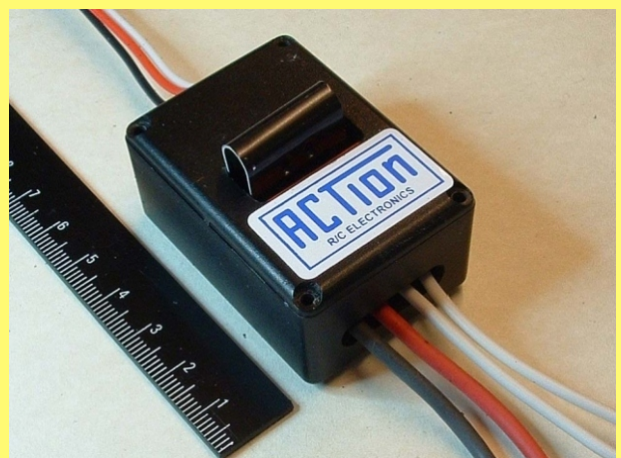

PICTURE 6: Follow instructions to cut hole in lid for heat-sink and slots in base for battery, motor and receiver leads.