

P49

MORSE/ALDIS SIGNAL REPEATER



This microcomputer unit will transmit Morse sound or light an Aldis lamp, or operate both alternately. It produces actual Morse messages (see below). Working on a battery of between 6 volts & 12 volts, it is intended to be switched on whenever the model is running but it can, of course, be switched by radio using a switcher if preferred (e.g. ACTION P44). A great project to add to your 'grey ships'.

MICROCOMPUTER AND MOS TRANSISTOR DESIGN

Morse or Aldis or both
Voltage requirement
Connections
Morse sounder
Bulb voltage
Maximum bulb wattage

Selectable by switch
6 volt to 12 volt
Screw connection
Ceramic sounder supplied only
To suit running voltage
15 watts (at run voltage)

STORED MESSAGES

- 1/"CQ Action Stations"
- 2/"Rejoin Convoy"
- 3/"Attack Attack, Delta 5 Procedure"
- 4/"Engage Target"
- 5/"CQ Report, Code"
- 6/"Make Best Speed"

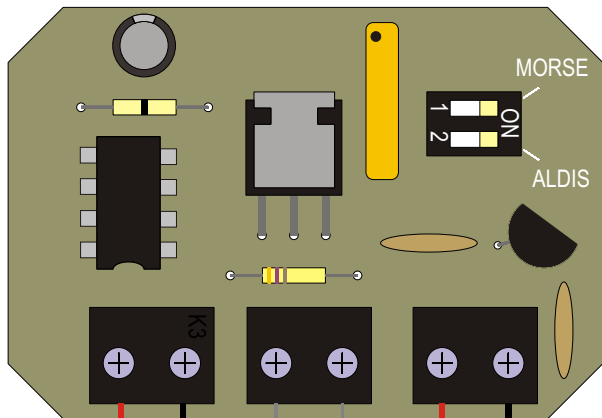

SOUNDER NOTE:
Do NOT use any other type of speaker or remove sounder from circuit

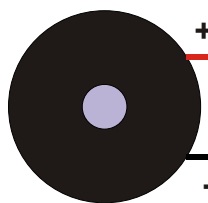

BULB

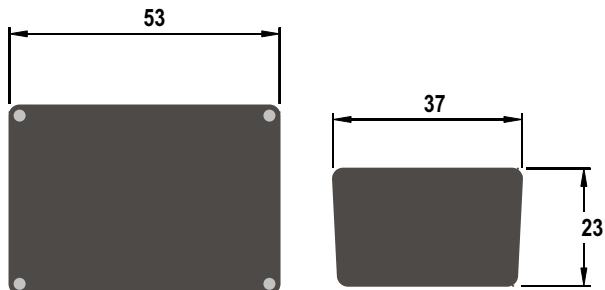

Case Dimensions

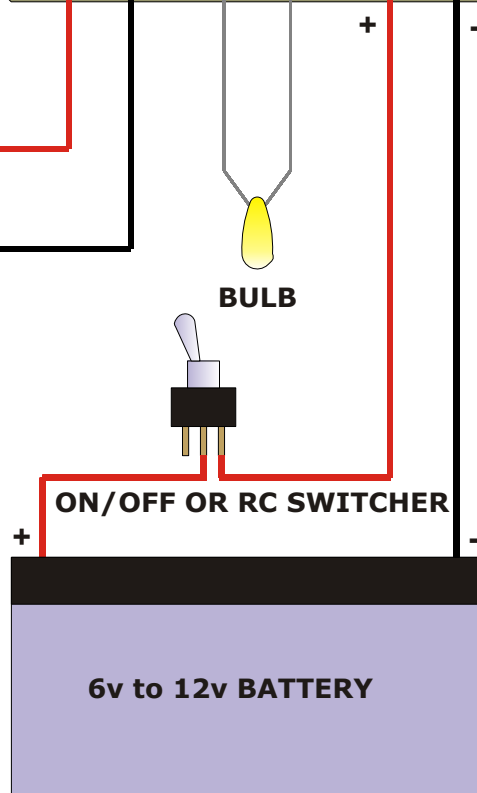

P49

MORSE/ALDIS SIGNAL REPEATER



This microcomputer unit will transmit Morse sound & light an Aldis lamp. It produces actual Morse messages. Working on a battery of between 6 volts & 12 volts, it is intended to be switched on whenever the model is running. It can, of course, be switched by radio using a switcher if preferred. A great project to add to your 'grey ships'.

STORED MESSAGES

- 1/ "CQ Action Stations"
- 2/ "Rejoin Convoy"
- 3/ "Attack Attack, Delta 5 Procedure"
- 4/ "Engage Target"
- 5/ "CQ Report, Code"
- 6/ "Make Best Speed"

SWITCH INFORMATION

(Miniature dual in-line switch, marked 1 & 2)

Switch 1ON	Switch 2OFF	= Morse sounder
Switch 1OFF	Switch 2ON	= Aldis drive
Switch 1 ON	Switch 2ON	= Alternate Morse and Aldis

Any changes should be made with the unit switched OFF, as they will only become effective on powering up.

Morse or Aldis or both
Voltage requirement
Morse sounder
Bulb voltage/Max power
Case size with screws

Selectable by switch
6 volt to 12 volt
Ceramic sounder supplied only
To suit running voltage; max 15W
54mm x 38mm x 23mm

INSTALLATION NOTES

The unit is polarity sensitive - make sure you connect the Red and Black wires from the battery to the correct terminals. Do not use any other kind of speaker; it won't work but it will destroy the unit

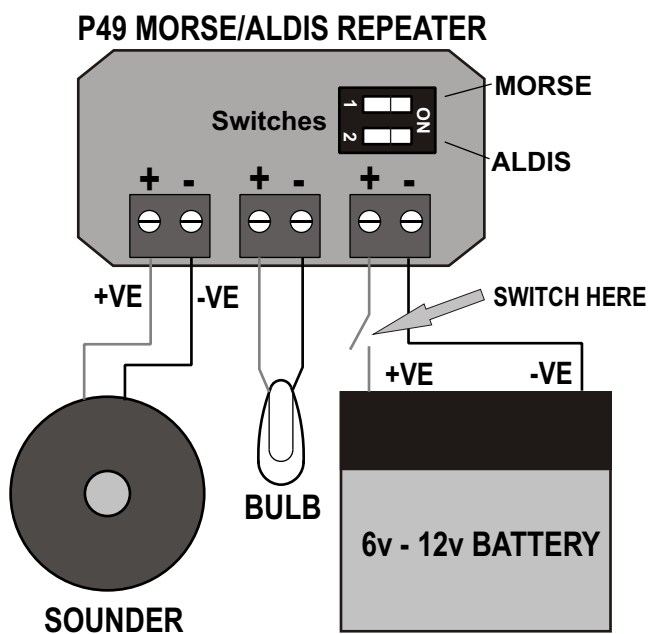

Don't leave the sounder out of the circuit, even if you only require to flash an ALDIS lamp, as it forms part of the circuit

For testing, position both of the dual miniature switches to ON. This will select alternate Morse and Aldis. Drill suitable holes in the ABS case for the wires to access the screw terminal connector blocks, and use Velcro pads to secure the case to the inside of the model.

FUNCTIONAL TEST

The unit will produce a half second of sound and light to show that the microcomputer has initialised correctly. **It will then time a period of thirty seconds** before transmitting a morse message. There will be another thirty-second wait; then an aldis message, and so on until all six messages have been sent. If left on it will go back to Message #1 again.

RECOVERY SERVICE

A recovery or repairs service ensures that you will not be left with a dead unit for any reason. The Service Charge for this kit is £13.00 including parts (including return shipping cost IN UK).

All returns should include full Credit Card details (Name & Address of cardholder, Card Number, Expiry Date, Card Security Number)

ACTION R/C ELECTRONICS, 1 Llwyn Bleddyn, Llanllechid, Bangor LL57 3EF United Kingdom

This unit is polarity-critical! Take care to connect the battery correctly!

The small print.....

ACTION R/C Electronics guarantee all products to be free from manufacturing defects for 12 months from date of purchase. This does not cover suitability for specific applications; components worn or damaged by use, tampering or incorrect connection; alteration to original components; damage to batteries or other equipment through use; misuse, or shipping damage. Where goods are found to be faulty, the customer shall return them to ACTION R/C Electronics in their original condition and with their original instructions, packaging etc. Our liability is limited to repairing or replacing goods to their original specification and will not exceed the cost of the goods. By using the product the user accepts all liability. Where a fixed repair charge is applicable, ACTION R/C Electronics shall undertake repairs to the extent that they are judged economically viable. Where such is not the case then the customer will be offered the option of crediting the repair charge towards the cost of a new unit or having the faulty unit returned and the charge refunded (less the cost of return carriage). We reserve the right to modify this guarantee without notice.



P49 MORSE/ALDIS DRIVER

Instructions for Kit version

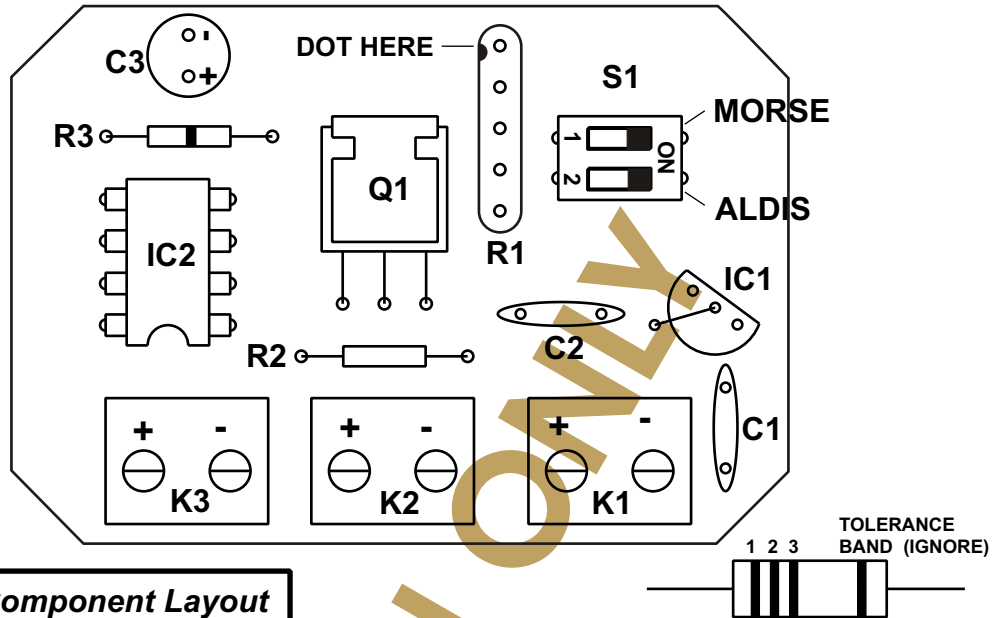

Component Layout

Resistor colour bands

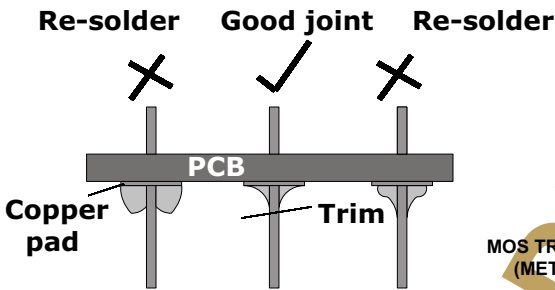

Soldering Tips

Component mounting details

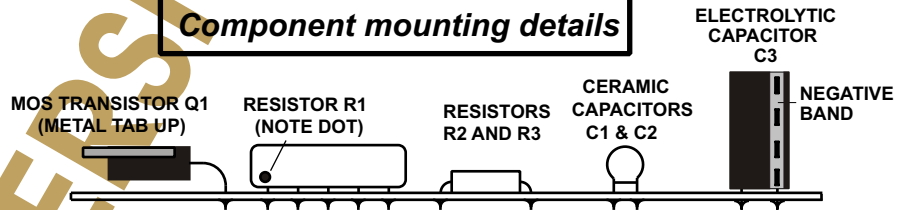

PARTS LIST

IC1	HT1050 IC REGULATOR.
IC2	PIC12C508 programmed IC (TAKE CARE WITH HANDLING) + 8 PIN IC SOCKET
Q1	14N05L MOS TRANSISTOR (TAKE CARE WITH HANDLING)
R1	THICK FILM RESISTOR PACK (4 x 100K)
R2	470 OHM RESISTOR 1/4 WATT (YELLOW/MAUVE/BROWN)
R3	ZERO OHM RESISTOR (ONE CENTRAL BLACK BAND)
C1,2	0.1 uF CERAMIC DISC CAPACITOR (marked 104)
C3	4.7uF MIN RADIAL ELECTROLYTIC CAPACITOR
C4	CASE TYPE RX2008 WITH 4 SCREWS
K1,2,3	2 WAY PCB SCREW CONNECTORS
PCB	Type P49
S1	SUB-MINIATURE DIL DUAL SWITCH
SOUNDER	HPE-270
WIRE	(Not supplied with kit) Any flexible wire.
BULB	(Not supplied with kit) 1Amp max current. SAME VOLTAGE AS THE BATTERY YOU USE.

P49 KIT INSTRUCTIONS

TOOLS

For construction you will require a soldering iron and flux cored solder (22 SWG is best); a small pair of wire cutters and a small screwdriver for the connection of power wires and (wire ended) bulb.

PARTS

DO NOT HANDLE ITEMS IN BLACK CONDUCTIVE FOAM Q1 AND IC2 UNTIL INSTRUCTED. (MOS DEVICES) THEY ARE SENSITIVE TO STATIC ELECTRICITY FROM YOUR BODY.

- The parts for the kit should be laid out on a clean surface so that they can be correctly identified.
 - The PCB has an insulated (Component Side) and a tinned track side. Components are mounted on the insulated side and soldered on the track side.
 - There are three different types of resistors in this kit, labelled on the Layout drawing as R1, R2, R3. The small rectangular pack with five legs is a pack of five resistors with a common connection R1. Information shown on the drawing will help you identify it and show which way to mount it. R2 is colour coded as directed in the PARTS LIST, and with the help of the small drawing Resistor Colour Bands. The other single resistor R3 is a zero Ohm resistor or link. It is marked with a central single black band.
 - The aluminium tube with a plastic sleeve is an electrolytic capacitor C3 and is marked with the value and working voltage, also a bar with Negative sign on it which signifies which leg goes to the negative. The opposite leg of the capacitor, of course, goes to the positive. C3 polarization is shown on the Layout drawing.
 - The small disc shaped components with two legs are ceramic disc capacitors C1 and C2. Both are the same value.
 - Q1 is a MOS transistor with three legs. Note carefully that it has an integrated heat sink (a metal tab) on one side and printed type identification on the other side. The Component Mounting Detail drawing shows how to mount it.
 - IC1 is a half-moon shaped black plastic moulding with three legs. Looking like an ordinary transistor it is actually a low current, low dropout stabilised power supply. IC2 is a microcomputer marked with the type code, 12C508. An IC Socket is supplied for IC2 so that the socket can be soldered and the IC can be fitted as the last operation.
 - S1 is a dual miniature switch. Each switch is numbered, and the ON position is clearly marked.
 - K1, K2, and K3 are PCB-mounting 2-way screw connectors to simplify wiring the finished unit.

CONSTRUCTION

NOTES ON MOS DEVICE HANDLING. USE A SHEET OF ALUMINIUM, COOKING METAL FOIL WILL DO. Place it on the work surface. Place the PCB, solder side down on it. Place the BLACK CONDUCTIVE FOAM on it, touch the metal with the soldering iron tip and then rest your hands on it, holding them there while you read through this part of the instructions. The PCB, any tools, the MOS IC and you are now all at the same potential, i.e. static neutralised. Q1 and IC2 should be fitted as the last operation in construction to avoid too much handling.

- With the exception of these two components, the other components can easily be fitted at any stage of the construction; a schedule of building order is not required. Just points to watch out for have been listed. Components can be fitted in whatever order you wish.
 - When fitting the IC socket and IC 2, ensure that the small notch at one end is in accordance with the illustration.
 - The polarity of capacitor C3 must be observed, see Layout and Mounting Detail drawings. The disc capacitors C1 and C2 can be fitted either way round. Surplus wire should be cut off after soldering.
 - Resistors R2 and R3 can be inserted either way round; just ensure that the correct one goes in the right place. Cut off the surplus wire after soldering. R1 must be mounted with the identifying dot as shown on the Layout drawing.
 - Q1 orientation is easy; refer to Layout and note that the metal tab or heat-sink is uppermost. See Component Mounting Details. Also the Switch S1 orientation is clearly marked.
 - K1, K2 and K3 must be mounted so that the wire holes face the outer edge of the PCB.
 - When the PCB construction is complete, the rear of the board can be cleaned with something like an old toothbrush and some spirit cleaner. Then check all over the soldered side of the board for good joints and no solder bridges between tracks. Time now to tackle the case; not a lot to it really, it's just a matter of drilling six small holes for the wires at the appropriate positions along the side of the case, or anywhere else that suits you. I personally just file a narrow slot for the length of the three sets of two holes in the connector block on the top edge of one side of the case. When you are sure that everything is as it should be, you can test.

TESTING

Having built the unit it's simply a matter of connecting your bulb across the two terminals labelled BULB (ensure that the bulb voltage is correct for the voltage that you are using). Next connection is to the SOUNDER, observing RED wire positive (+) and BLACK wire negative (-). Then connect the power wires from whatever battery you are using, observing the same BLACK/RED wiring convention. You don't need a switch to test it initially; it can be connected to the drive battery. You will need to switch the circuit on and off when finally installed in the model.

WHEN THE UNIT IS SWITCHED ON, IC2 CHECKS TO SEE WHICH SWITCHES HAVE BEEN SELECTED AND THEN INDICATES POWER UP WITH A HALF SECOND SOUND AND LIGHT SIGNAL. THIS IS FOLLOWED BY A 30 SECOND PAUSE BEFORE THE FIRST MESSAGE IS SENT.

P49 MORSE/ALDIS

PHOTOGRAPHIC BUILD SEQUENCE FOR KIT VERSION

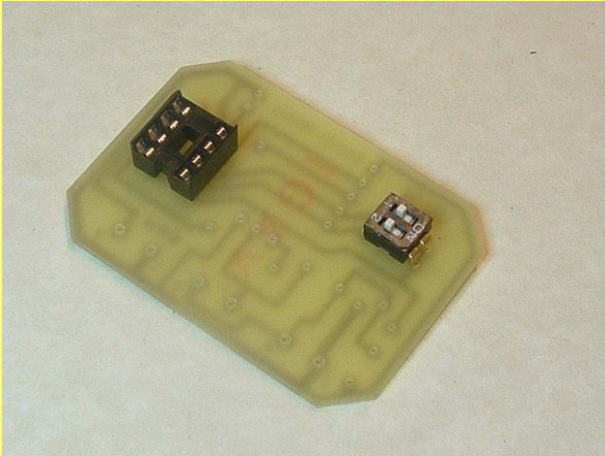

PICTURE 1: PCB with I/C socket and 2-way DIP switch fitted

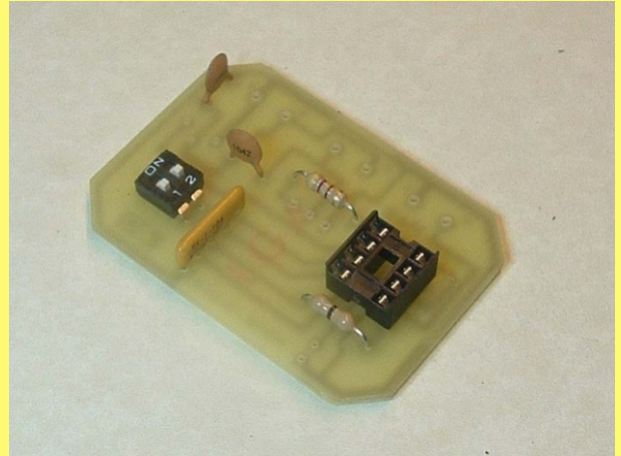

PICTURE 2: Resistors and ceramic capacitors added

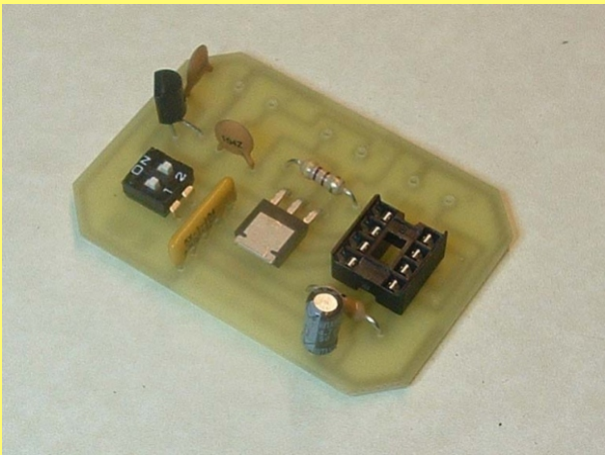

PICTURE 3: FET, 5v regulator and electrolytic capacitor added

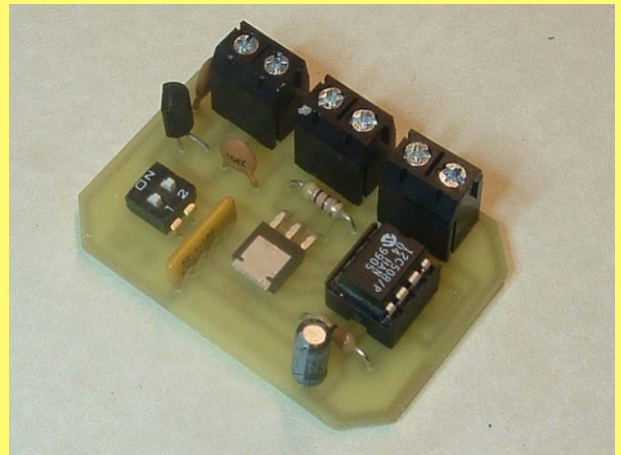

PICTURE 4: Fit screw terminals. Plug in I/C last of all NOTE! ANTI-STATIC PRECAUTIONS REQUIRED

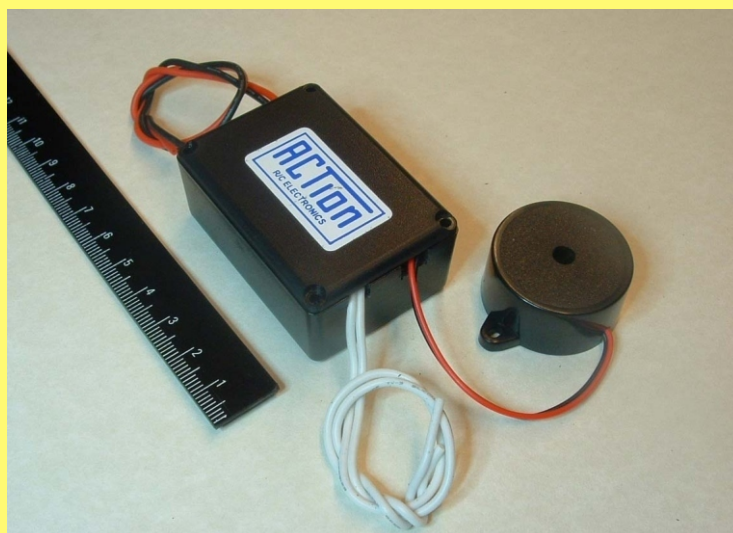

PICTURE 5: Finished unit in case, with sticker. Sounder is part of circuit and must NOT be substituted or left out. White wires are connections to ALDIS bulb(s).