

Phase #1 - Motor speed only

SUGGESTED INSTALLATION OF ACTION UNITS IN 36" FISHING COBLE FOR Mr Tony Cousins

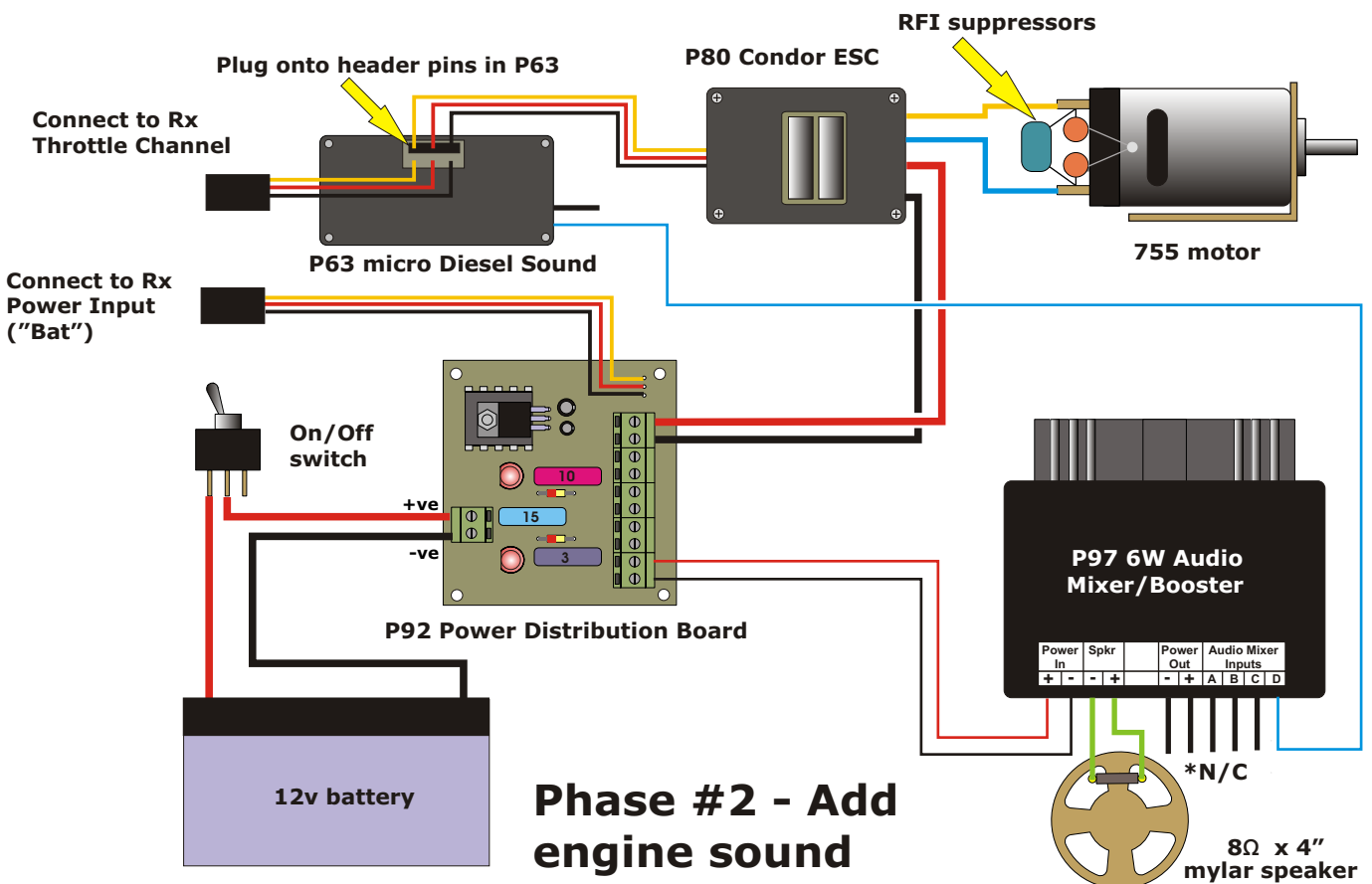

Phase #2 - Add engine sound